

Micro Hardness Tester for Vickers and Knoop

Starrett®



3841 Series

Contents

1. Introduction
2. Main Technical Specifications
3. Installation and Regulation of the Instrument
 - 3.1 Operational conditions
 - 3.2 Unpacking and installation
 - 3.3 Introduction to the operating board and its function keys
4. Usage of the Instrument
5. Calibration and Precautions of the Instrument
6. Accessories (The Packing List)
7. Special Accessories

**TECHNICAL SUPPORT:
(201) 962-8352**

3 Unpacking, Operational Conditions and Installation

Unpacking and Installation

Cut the belt on packing crate; remove the anti-shock cushion and remove the instrument and the accessories kit from the crate.

Place the instrument on the prepared solid working table; (for the construction of the working table, see Fig 1)

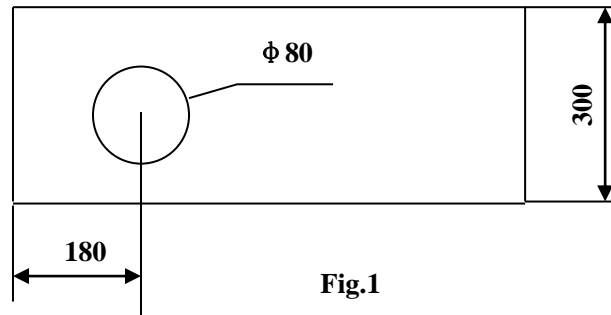

IMPORTANT!

Do Not Discard Shipping Crate as This May
be Needed for Future Transportation.

General Safety Instructions

1. Never use clamps, straps, any other tooling or equipment to mount specimen to the tester anvil.
2. Always use the proper anvil supplied.
3. Be sure to use proper indenter and weight for material and hardness to be tested.

Hardness Tester Should Be Maintained

1. Consult operation instructions for specific maintaining and adjusting procedures.
2. Keep the tool clean for best results.
3. Remove adjusting tools and wrenches. Form habit of checking that adjusting tools are removed before using machine.
4. Keep all parts in working order. Check to determine that the parts will operate properly and perform their intended function.
5. Check for damaged parts. Check for alignment, binding, breakage, mounting and any other condition that may affect tool's operation.
6. Part that is damaged should be properly repaired or replaced. Do not perform makeshift repairs. (Use the parts list provided to order replacement parts.)

Micro Hardness Tester for Vickers and Knoop

Operating Conditions:

The 3841 Micro Vickers Hardness Tester is a precise yet sensitive instrument that should be handled with care. Please be sure to mount on a sturdy bench in a clean temperature-controlled room for best results. This instrument should be perfectly level before performing any tests.

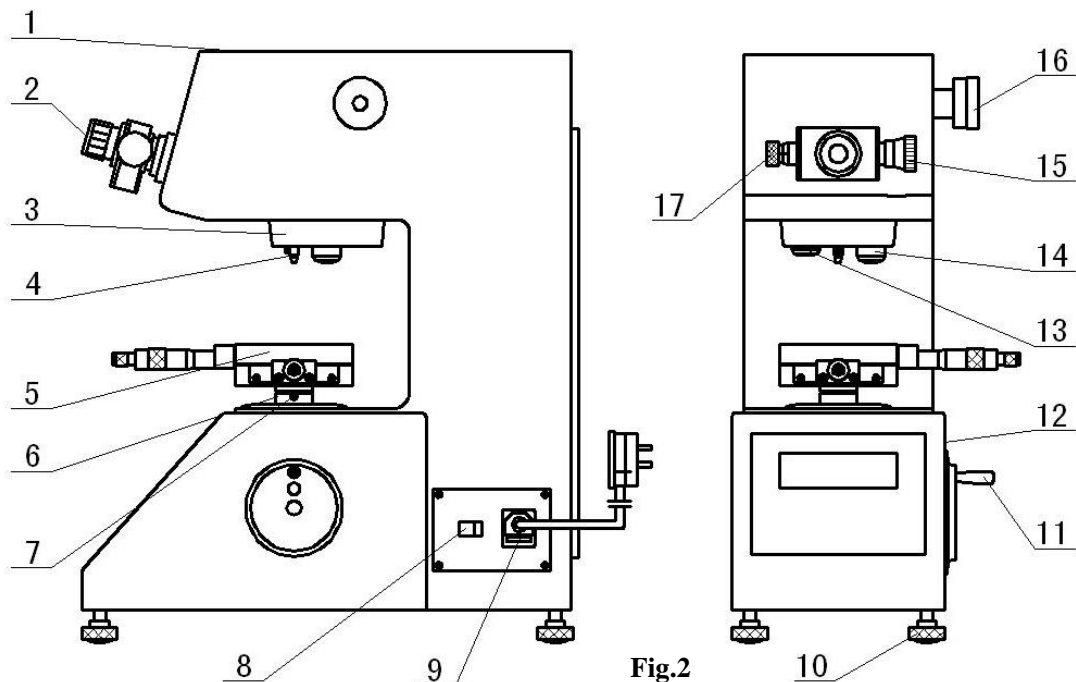

1. Upper Cover 2. Microscope 3. Rotating Plate 4. Indenter 5. Cross Testing Table
6. Up and Down Lead Screw 7. Screw 8. Power Switch 9. Power Cord and Fuse
10. Leveling Feet 11. Hand Wheel 12. Screen 13. 10× Objective 14. 40× Objective
15. Right Drum Wheel 16. Load-Change Hand Wheel 17. Left Drum Wheel

Set Up - Installation:

Take out the 4 Leveling Feet (10) out of the accessories kit and screw them in the holes on the base panel of the instrument. Unpack the gauze band wrapped on the Up and Down Lead Screw (6) and Hand Wheel (11) (Fig.2).

Gently remove the anti-shock paper on the indenter with both the hands. Clean the indenter gently with rubbing alcohol.

RECOMMENDATIONS:

- a) Use a good quality UL listed Power Strip w/Surge Protector
- b) You should use a powered USB Hub/Expander to hook up the video camera. This will prevent errors that may occur due to lack of power on the USB port in your PC.

Micro Hardness Tester for Vickers and Knoop

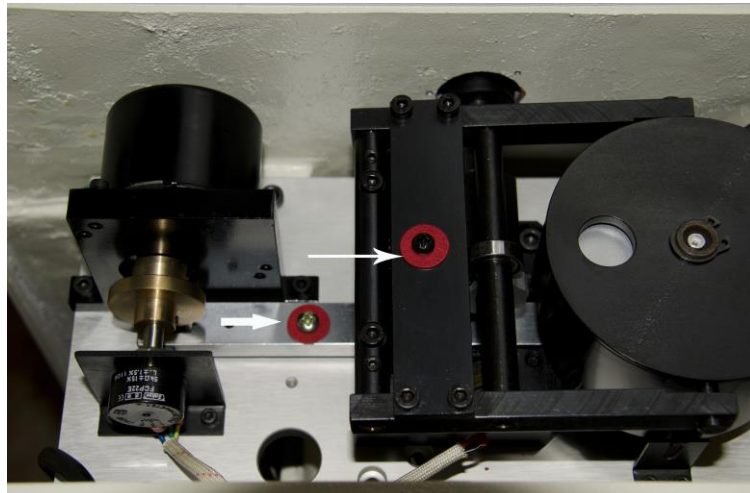

Fig.3

Open the Upper Cover of the machine and remove the two Anti-Shock Screws as shown in Fig.3.

Remove the protective paper on the Weight Seat and remove the Weight Seat Cover. Take the Weight shaft (21) and Weights (22) out of the accessories kit and clean them thoroughly. (Clean the supporting surface of the Weight Axis with cloth dipped with some oil so as to protect it against rust.) Put the six Weights on the Weight Axis in the order from small to big (see Fig 4).

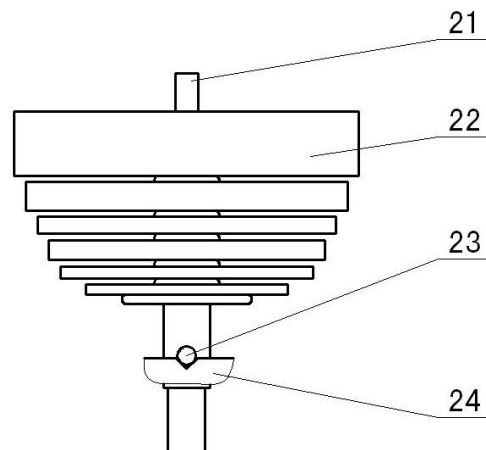
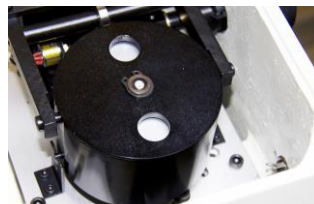
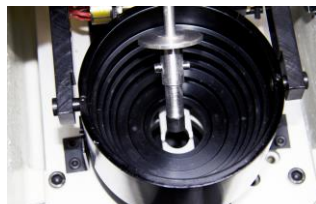

Fig.4

- 21.Weight Shaft 22.Weights
- 23.Weight Shaft Peg 24. V-Shaped Groove

Hold the top of the Weight shaft, put the Weight shaft into the Weight Seat and rotate the Weight shaft so that the Weight shaft Peg (23) may fall into the V-shaped Groove (24) of the lever.

Cover the Weight Seat with the Weight Seat Cover.



Micro Hardness Tester for Vickers and Knoop

Rotate the Load-Change Hand Wheel (16) of testing force, so as to make the Weight Seat move up and down smoothly on the groove;

Take the dust-protecting cover of the eyepiece tube out and insert the Microscope (2) into the hole of eyepiece tube until its flush.

Take the Cross Testing Table (5) out of accessories kit and clean off the rust protecting oil on it.

Insert the shaft of the Cross Testing Table into the hole on the Up and Down Lead Screw and tighten it with the Screw (7).

Take the supplied bullseye level out of the accessories kit and put it on the Cross Testing Table, and then adjust the leveling feet accordingly.

KEYPAD FUNCTIONS: (Fig.5).



1. The shifting key between Micro Vickers and Knoop mode.

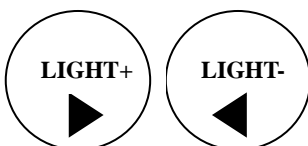

1. Addition key and reduction key for the light source.

2. Left and right moving key for the hardness conversion scale.

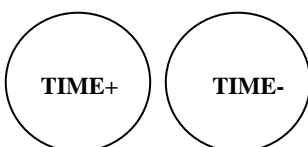

Dwell time adding and reducing key. Every pressing turns 5 seconds.

Micro Hardness Tester for Vickers and Knoop

Double pressing this key means confirmation. For example: after key in D1 value 202, double press this key to confirm D1. As same, after key in D2 value 203.5 double press this key to confirm D2. The hardness value on the screen will be “HV: 721.4”.

SPEC key is special function key. Single press this key, then press key to let Upper keys become valid. And as the same, single press SPEC key, then press ∇ key to let Lower keys become valid.



Zero setting key: Press this key to set the two graduated lines zero.

Scale conversion key: When need to select conversion scale, press spec key and make this key valid. The default value is HRC.



Test force application key.

4 Usage of the Instrument

Slowly, gently rotate the Load-Change Hand Wheel to make the testing force meet the requirements of the application.

For Models 3841C & 3841D

Turn the Power Switch (8) on and the Screen (12) will show the Model of hardness tester and then will display the Time and Date and at this moment you must press the HV/HK button to allow the auto-turret to function and allow the unit to communicate with your PC. Once completed the display will show the main testing screen as shown below.

D1: 0.0	HV:	
D2:	T:15	N:00

Adjusting Light Source: Press the “L+” or “L-” buttons to adjust the brightness for your optimal vision.

Dwell Time Setting: The 3841 is preset at 15 seconds since this is the most common time needed for a micro Vickers test. You can adjust this time by pressing the “T+” or “T-“ buttons. Each button press will add or subtract 5 seconds from the preset time.

Setting the Eyepiece: Turn the Rotating Plate (3) to make the 40×objective (14) face in the front direction. The general amplification is 400× (The eyepiece, objectives and specimen are in the focusing state).

Micro Hardness Tester for Vickers and Knoop

Taking a Test: Place the supplied hardness test block or a known specimen on the Testing Table and then rotate the Hand Wheel to raise the Testing Table. Look through the Eyepiece to observe. When the hardness block or the specimen comes into the distance of 1~2 mm under the Objective, at this point, in the center of the vision field of the Eyepiece appears a bright spot, which shows it is very close to the focusing plane. At this time, continue raising the Testing Table up slowly until the hardness block or specimen surface forms a clear image in the Eyepiece. If two moveable graduated lines

observed in the vision field of the Eyepiece seem vague, turn the eye guard on the Eyepiece to bring into clear focus. You should now see the grain of the block very clearly.

Press the “START” button on the keypad and the indenter rotates automatically to the working position.

The 3841 will apply the testing force automatically and the (LOADING) LED flashes. After the test force application is completed, the (DWELL) LED lights up, and at this time, the T (Dwell Time) indicated on the LCD screen shows countdown to 0. After the dwell time of test force is completed, the (UNLOADING) LED flashes, and the instrument automatically unloads the testing force. After the (UNLOADING) LED is off, the 40^x objective will automatically turn to the working position (face in front direction of the instrument) automatically. The unit will beep when ready.

Turn the Indenter to the front direction of instrument. At this point, the distance between the tip of Indenter and the plane of specimen is about 0.4~0.5 mm.

IMPORTANT! When testing an irregular-shaped specimen, take care not to damage the indenter when turning the plate.

Press the red START button and the instrument will begin by putting the load on. The red light by the Loading sign on the left side of the keypad will blink. After the load has completed, the (Dwell) LED lights up, and at this time the dwell time begins counting down to “0”. After the dwell time of test force is up, the (Unloading) LED blinks, and the instrument automatically unloads the testing force. The instrument will beep when this is done.

Measuring the Indentation:

Turn the 40^x Objective to face in front direction, observe the indentation in the eyepiece; rotate the Hand Wheel to focus microscope until the image quality of indentation becomes clear.

Micro Hardness Tester for Vickers and Knoop

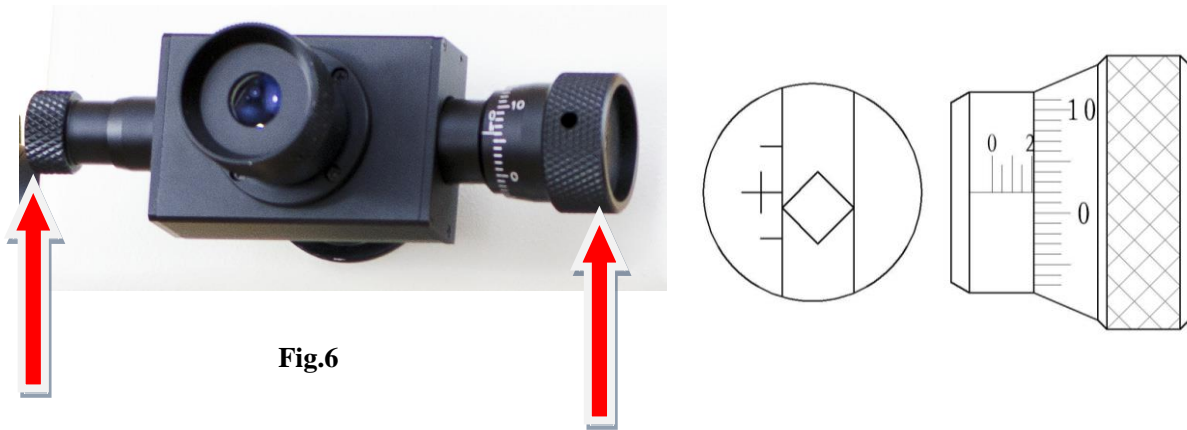

Fig.6

Rotate the Left Drum Wheel (17) as shown above to enable the inner side of left graduated line tangent to the left tip of the diagonal line of the indentation. Rotate the Right Drum Wheel (15) as shown above to enable the inner side of right graduated line tangent to the right tip of the diagonal line of the indentation (Fig.6).

Each rotation or cycle of the Right Drum Wheel is 50 grids. If it turns 4 cycles and over 2 grids, that means $50 \times 4 + 2 = 202$ grids. This is the number that you will be entering on the display using the keypad.



Once the measurement explained above has been obtained, you must now press the "SPEC" key and " Δ " key, the cursor will blink and now ready for values to be entered. See picture below:

Micro Hardness Tester for Vickers and Knoop



Key in digit 202, then press “SPEC” key TWICE to confirm D1 value. The cursor will move to D2 and is ready for the second measurement.



Turn the Eyepiece by 90°. Measure the other diagonal line length the same way you did the first measurement. Key in digit 203.5; double press “SPEC” key to confirm D2 value. The screen will show hardness value automatically: “HV: 721.4”.

Micro Hardness Tester for Vickers and Knoop



If the operator is not sure of the correctness of present measurement, please key in D1 and D2 values (grids) again.

After this measurement is completed, press the "SPEC" key; then press the "▽" key to let the cursor disappear. The instrument is now ready for the next test.



If you find the Indenter does not face in front direction after you pressed "START", it is prohibited to turn the Rotating Plate until the loading, dwelling and unloading process are completed finish (3 LED are all black out). Only the entire testing cycle is completely finished, the position of the Indenter can be changed, otherwise, the instrument will be

5 Calibration and Precautions

The Eyepiece

If the graduated lines observed in the vision field of the Eyepiece are blurry or not clear, you should adjust the clarification by slightly turning the eye guard in front of the eye piece accordingly.

The Eyepiece should be inserted to the bottom of eyepiece tube with no space between them, otherwise it would affect the correctness of the measurement.

When a larger vision field on the specimen is observed, turn 10× Objective to face in front direction of instrument. At this time, the general amplification is 100× and it is for observation purposes only.

Micro Hardness Tester for Vickers and Knoop

If the indentation observed from the Eyepiece is too small or too large and it would affect the measurement accuracy, please select new test force again to meet the needs of requirement for measurement and repeat the test.

Due to the difference of surface roughness and flatness on the specimen, the indentation may be deformed, therefore, two diagonal line length of indentation should be measured in two mutually perpendicular directions.

When testing the Knoop hardness value, only the long diagonal line length of indentation should be measured. The Knoop hardness value (HK) will be displayed directly.

Calibrating the eye piece:

The zero position of the Eyepiece was calibrated before the instrument was re-created. During usage over time, it may be the cause of an error, therefore, zero position setting should be carried out periodically. As soon as an error appears, the zero position shall be regulated.

Regulation Method: Turn the Drum Wheels to enable inner sides of two graduated lines to come close together until the point that no light is visible between them. This doesn't mean one line on top of the other. Its more like one line is to the side of the other. The "0" positions of Right Drum Wheel also should be aligned as well. If the "0" positions are not aligned, loosen the screw, align the zero positions, then fasten the screw (Fig.7).

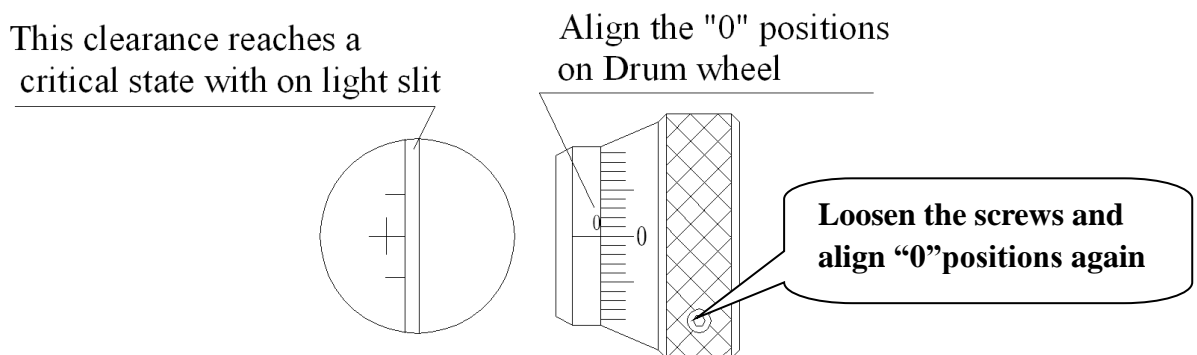

Fig. 7

The Indenter

The diamond Indenter and indenter axis are important parts of the instrument, and hence it is necessary to take care not to collide with the Indenter during the operation.

In order to assure the precision of the measurement, it is important to keep the Indenter clean. If it is covered with grease or dust, it should be cleaned carefully with absorbent cotton dipped with rubbing alcohol.

The round column of the Indenter is marked with a red dot. When changing the indenter, take care to make the red dot face the front direction when it is reloaded, and the focus of the diagonal lines of the indentation should be aligned with the red dot. It is possible to make the alignment of the cross-shaped line in the eyepiece with the diagonal lines of the indentation. If the indentation observed is not aligned with the cross-shaped line, please unscrew the screw on the Indenter, turn the Indenter a bit and the fasten the screw, and then make the alignment again through tests until the alignment is all right to your satisfaction (See Fig.8)

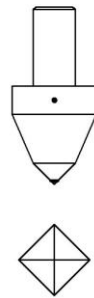

Fig.8

The specimen

The surface of the specimen must be clean or penetration and/or measuring results may be distorted. Please clean the specimen with alcohol or other safe cleaner.

When thin filaments, thin pieces and small parts are used as the specimens, the fine wire testing table, thin specimen testing table and the fork-shaped testing table should be used to hold the specimens respectively on the Cross Testing Table for the measurement. If the specimen is too small to be held by the testing table, the specimen should be inlaid and polished for the measurement.

Usage Method of Knoop (HK) Hardness

7 Sample Introduction of Knoop Hardness

The distinguishing characteristic of Knoop test is the improvement on the indenter's design. You only need to measure the long diagonal line length of indentation, therefore the relative error of measurement becomes smaller. Compared to the micro Vickers test, when press the test force with same value, the indentation of a Knoop hardness test is shallower, hence, it is suitable to test the thin sheet parts. It is used to test brittle and hard materials such as enamel, glass, agate, man-made precious stone, ceramic metals, etc.

Usage of Hardness Tester

When replacing the Knoop indenter, the red point on the outer cylinder of indenter should face to front of the machine (see Fig.9).

Operate the key on operation board to enable the testing method change to "HK", the Knoop hardness test method.

D1: 0.0	HK:
	T:10
	N:00

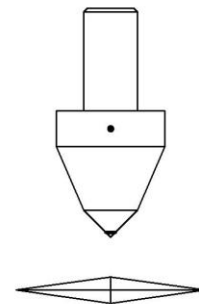

Fig.9

7.2.3 The operation method is just as same as that of micro Vickers hardness test, see Section 4.

7.2.4 Only required to measure the long diagonal line length of the indentation; then input the read digit. The Knoop hardness value (HK) will be displayed on the screen.

7.3 The Max. Allowed Tolerance of Displaying Value

Hardness Scale	Test Force (N)	Max Allowed Tolerance of Display Value %								
		Hardness Value (HK)								
		50	100	150	200	250	300	350	400	450
HK0.01	0.098	5	6	7	9	9	10	11	-	-
HK0.025	0.245	5	5	5	6	6	7	7	8	8
HK0.05	0.49	5	5	5	5	5	5	5	6	6
HK0.1	0.98	5	5	5	5	5	5	5	5	5
HK0.2	1.961	5	5	5	5	5	5	5	5	5
HK0.3	2.942	5	5	5	5	5	5	5	5	5
HK0.5	4.903	5	5	5	5	5	5	5	5	5
HK1	9.807	5	5	5	5	5	5	5	5	5

Micro Hardness Tester for Vickers and Knoop

Hardness Symbol	Max Allowed Tolerance of Display Value $\pm\%$															
	Hardness HV															
	50	100	150	200	250	300	350	400	450	500	600	700	800	900	1 000	1 500
HV 0.01																
HV 0.015	10															
HV 0.02	8															
HV 0.025	8	10														
HV 0.05	6	8	9	10												
HV 0.1	5	6	7	8	8	9	10	10	11							
HV 0.2		4		6		8		9		10	11	11	12	12		
HV 0.3		4		5		6		7		8	9	10	10	11	11	
HV 0.5		3		5		5		6		6	7	7	8	8	9	11
HV 1		3		4		4		4		5	5	5	6	6	6	8
HV 2		3		3		3		4		4	4	4	4	5	5	6
HV 3		3		3		3		3		3	4	4	4	4	4	5
HV 5		3		3		3		3		3	3	3	3	3	4	4
HV 10		3		3		3		3		3	3	3	3	3	3	3
HV 20		3		3		3		3		3	3	3	3	3	3	3
HV 30		3		3		2		2		2	2	2	2	2	2	2
HV 50		3		3		2		2		2	2	2	2	2	2	2
HV 100				3		2		2		2	2	2	2	2	2	2

1 When the indentation diagonal length is less than 0.020 mm, the table will not display the value.

2 For intermediate values, the maximum allowable error can be obtained by interpolation.

3 When the Micro Hardness Tester value in the table is 0.001mm or indentation diagonal length of the average of 2% of the maximum permissible error given, please select the higher value.

Micro Hardness Tester for Vickers and Knoop

Packing List:

The main instrument (including a micro Vickers Indenter, a 40^X Objective and a 10^X Objective)

Item	Descriptions	Quantity
1	Weights	6 PCS
2	Weight Shaft	1 PC
3	Cross Testing Table	1 PC
4	Thin Specimen Testing Table	1 PC
5	Fork-Shaped Testing Table	1 PC
6	Fine Wire Testing Table	1 PC
7	Screw Drivers	2 PCS
8	Leveling Feet	4 PCS
9	Bullseye Level	1 PC
10	Power Cord	1 PC
11	Prepare Fuses (1A)	2 PCS
12	10 ^x Digital Micro Eyepiece	1 PC
13	Vickers Hardness Blocks	2(one mid range HV0.2 block and one high HV1 block)
14	Operation Manual	1 PC

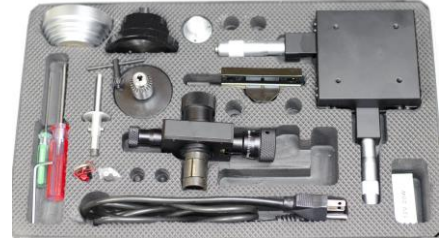

TECHNICAL SUPPORT:
(201) 962-8352