



Model No. 3834 **TWIN Rockwell/Superficial
Rockwell Hardness Tester**
w/Closed Loop Load Cell Technology!



Operating Instructions & Parts Manual

*Please read and save these instructions. Read carefully before attempting to assemble, install, operate or
Protect yourself and others by observing all safety information.*

Failure to comply with instructions could result in personal injury and/or property damage! Retain Instructions for future reference.

TECHNICAL SUPPORT: (201) 962-8352

Web Site: <http://www.starrett.com>

Operating Instructions & Parts Manual

The 3834 Digital Rockwell/Superficial Hardness Tester can be used directly to measure the most popular regular and superficial Rockwell hardness scales and quickly convert that hardness value into HB, HV, HLD, HK and many other scales. Loaded with many useful features such as ultra-precise results, wide measuring range, scale and test force selectable, automatic main test force loading/unloading, high resolution digital display and USB data storage. The 3834 is suitable for testing hardness of carbon steel, alloy steel, cast iron, non ferrous metals and engineering plastics.

2. Scale, Indenter, Test Force and Application Scope for Rockwell Hardness

Scale Symbol	Indenter Type	Preliminary Force N (kgf)	Total Force N (kgf)	Typical Applications
A	Spheroconical Diamond	98.07 (10)	588.4 (60)	Cemented carbides, thin steel, and shallow case hardened steel
B	1/16" Carbide Ball	98.07 (10)	980.7 (100)	Copper alloys, soft steels, aluminum alloys, malleable iron, etc.
C	Spheroconical Diamond	98.07 (10)	1471 (150)	Steel, hard cast irons, pearlitic malleable iron, titanium, deep case hardened steel, other harder than HRB 100
D	Spheroconical Diamond	98.07 (10)	980.7 (100)	Thin steel and medium case hardened steel, and pearlitic malleable iron
E	1/8" Carbide Ball	98.07 (10)	980.7 (100)	Cast Iron, Aluminum and magnesium alloys, and bearing metals
F	1/16" Carbide Ball	98.07 (10)	588.4 (60)	Annealed copper alloys and thin soft sheet metals
G	1/16" Carbide Ball	98.07 (10)	1471 (150)	Malleable irons, copper-nickel-zinc and cupro-nickel alloys
H	1/8" Carbide Ball	98.07 (10)	588.4 (60)	Aluminum, zinc and lead
K	1/8" Carbide Ball	98.07 (10)	1471 (150)	Bearing Metals and other very soft or thin materials. Use smallest ball and heaviest load that doesn't give anvil effect.
L	1/4" Carbide Ball	98.07 (10)	588.4 (60)	
M	1/4" Carbide Ball	98.07 (10)	980.7 (100)	
P	1/4" Carbide Ball	98.07 (10)	1471 (150)	
R	1/2" Carbide Ball	98.07 (10)	588.4 (60)	
S	1/2" Carbide ball	98.07 (10)	980.7 (100)	
V	1/2" Carbide ball	98.07 (10)	1471 (150)	
15N	Spheroconical Diamond	29.42 (3)	147.1 (15)	
30N	Spheroconical Diamond	29.42 (3)	294.2 (30)	
45N	Spheroconical Diamond	29.42 (3)	441.3 (45)	
15T	1/16" Carbide Ball	29.42 (3)	147.1 (15)	Similar to B, F and G scales but for thinner gage material.
30T	1/16" Carbide Ball	29.42 (3)	294.2 (30)	
45T	1/16" Carbide Ball	29.42 (3)	441.3 (45)	
15W	1/8" Carbide Ball	29.42 (3)	147.1 (15)	Very Soft Material
30W	1/8" Carbide Ball	29.42 (3)	294.2 (30)	
45W	1/8" Carbide Ball	29.42 (3)	441.3 (45)	
15X	1/4" Carbide Ball	29.42 (3)	147.1 (15)	
30X	1/4" Carbide Ball	29.42 (3)	294.2 (30)	
45X	1/4" Carbide Ball	29.42 (3)	441.3 (45)	
15Y	1/2" Carbide Ball	29.42 (3)	147.1 (15)	
30Y	1/2" Carbide Ball	29.42 (3)	294.2 (30)	
45Y	1/2" Carbide Ball	29.42 (3)	441.3 (45)	

TECHNICAL SUPPORT: (201) 962-8352

Web Site: <http://www.starrett.com>

2 Key performance parameters

- **Preload:** *Rockwell:* 98.1N (10kgf) *Superficial:* 29.42N (3kgf)
- **Total test force:** *Rockwell:* 588.4N(60kgf), 980.7N(100kgf), 1471N(150kgf),
Superficial Rockwell: 15kgf(147.1N)、30kgf (294.2N)、45kgf (441.3N)
- **Scales:** HRA, HRB, HRC, HRD, HRE, HRF, HRG, HRH, HRK, HRE, HRL, HRM, HRP, HRR, HRS, HRV HR15N、HR30N、HR45N、HR15T、HR30T、HR45T、HR15W、HR30W、HR45W、HR15X、HR30X、HR45X、HR15Y、HR30Y、HR45Y
- **Load dwell duration:** 2~50s
- **Resolution :** 0.1HR
- **Display:** High definition backlight LCD
- **Operation:** Menu selectable push buttons
- **Auxiliary functions:** Upper/lower limits setting& alarm,
Scale conversions: HV & HB
- **Data output:** USB memory stick
- **Testing Capacity:** *Vertical:* 8.00” *Throat Depth:* 7.87”
- **Dimensions:** *Height:* 22.04” *Width:* 8.07” *Depth:* 31.49” (560mm×205mm×800mm)
- **Power supply:** single phase, AC, 110V, 50~60Hz, 4A
- **Gross weight:** 175lbs (80kg)

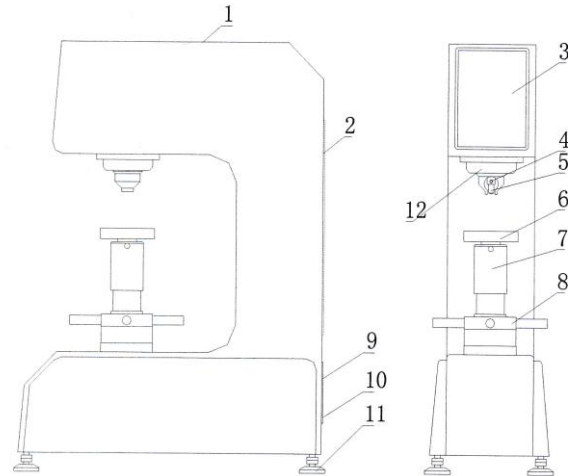

Fig.4-2

- 1.Top Cover 2.Back Cover 3. Touch Screen 4.Indenter Screw**
5.Indenter 6.Anvil(test table) 7.Dust Cover 8.Elevating Wheel
9.Power Switch 10.USB Port 11.Leveling Feet(4) 12.Indenter Protector

Uncrating the hardness tester

Cut the straps on the packing crate, remove the screws on the bottom plate of the box and remove off the upper body of the crate. Remove the accessories kit.

Unscrew the two M10 outer hex bolts under the bottom plate to separate the hardness tester from the bottom plate

CAUTION! *Should be performed with minimum of 2 people for safety.*

Installation of the hardness tester

The machine should be mounted on a firm bench or table in a clean area, free from vibration or shock, recommended height is approx. 30". A 2" hole must be drilled in the top of the work bench to allow maximum travel of lead screw.

Refer to figure 4. 1.

Place the tester on the prepared bench, turn the hand wheel counter-clockwise to lower the anvil, remove the anti-vibration pad. Take out 4 Leveling Feet from accessories kit and screw them in the holes on the bottom corners of the hardness tester.

Place the small flat anvil in the lead screw and place a precision level on the anvil, adjust the leveling feet of tester to make the level within +/- 1mm/m, then lock the nuts.

See drilling dimension below:

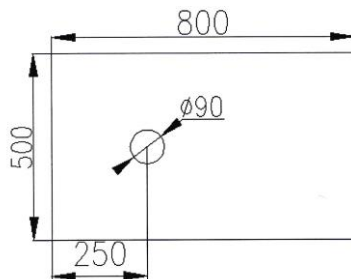

Option Cabinet/Stand is available:



TECHNICAL SUPPORT: (201) 962-8352

Web Site: <http://www.starrett.com>

Setting Parameters: *All can be set using the intuitive touch screen display.*

Main Touch Screen Interface:

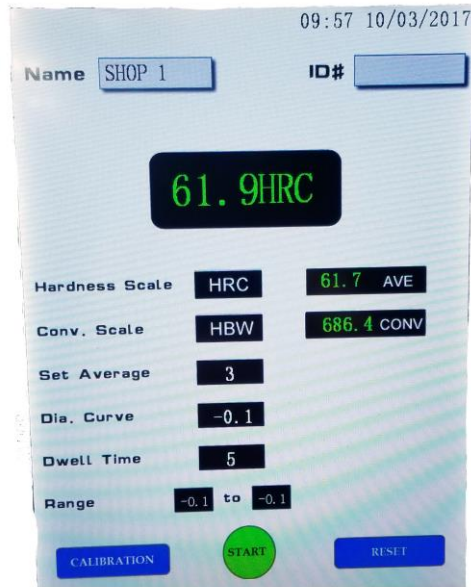

Entering Operation Name / Item ID:

Touch the screen to the right of "NAME" and/ or "ITEM ID" and the alpha-numeric interface will be shown on the display as shown below.

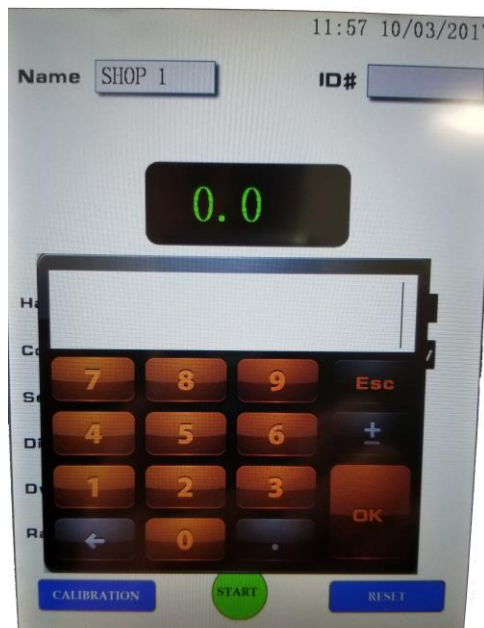

Use the touch screen to enter the information and then touch the "OK" button on the screen to save and return to the main testing screen.

TECHNICAL SUPPORT: (201) 962-8352

Web Site: <http://www.starrett.com>

Operating Instructions & Parts Manual

Entering Diameter of Curvature: *For testing round parts only!*

Touch the screen to the right of “Diameter of Curvature” and the numeric interface will be shown on the display as shown below



Use the touch screen to enter the diameter and then touch the “OK” button on the screen to save and return to the main testing screen.

Entering Range: (Min/Max setting)

Touch the screen to the right of “RANGE” and the numeric interface will be shown on the display as shown below.

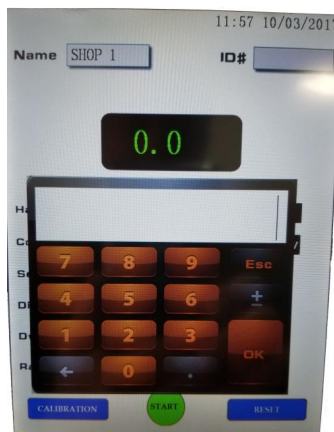

Use the touch screen to enter the LOW RANGE and then repeat for the HIGH RANGE and then touch the “OK” button on the screen to save and return to the main testing screen

TECHNICAL SUPPORT: (201) 962-8352

Web Site: <http://www.starrett.com>

Entering Hardness Scale:

Touch the screen to the right of “HARDNESS SCALE” and the scale selection screen will be shown as below:



Use the touch screen to choose your desired hardness scale. Once selected, the display will change back to the main testing screen. Next use the weight selector knob on the right side of the machine and make sure you choose the proper load for the hardness scale chosen. Be sure that you also use the correct indenter for the selected load. If you are unsure then reference the weight load/indenter chart shown in the back of this manual.

Entering Conversion Scale:

Touch the screen to the right of “CONVERSION SCALE” and the conversion selection screen will be shown as below.



Use the touch screen to choose the scale. The display will then change back to the main testing screen.

Operating Instructions & Parts Manual

Entering Dwell Time: *This is the amount of time the major load is being applied to the sample. Recommended time is 5 seconds for basic Rockwell.*

Touch the screen to the right of “DWELL TIME” and the numeric interface will be shown as below.



Use the touch screen to choose the dwell time and touch “OK”.
The display will then change back to the main testing screen.

Entering Time and Date:

Touch the screen where the time and date is shown in the top right corner of the display. The numeric interface will be shown as below.



Use the touch screen to choose the Date & Time and touch “OK”.
The display will then change back to the main testing screen.

TECHNICAL SUPPORT: (201) 962-8352

Web Site: <http://www.starrett.com>

Operating Instructions & Parts Manual

CALIBRATION:

The calibration was set prior to delivery and should not be needed. However due to shipping and movement thereafter you may need to make some slight adjustments. Its advisable that you contact our tech support team for assistance. **Call (201) 962-8352**

Step 1) Using one of the supplied test blocks, take a minimum of 3 tests and obtain your average.

Step 2) Press the CALIBRATION button on the main display.

See calibration display below:

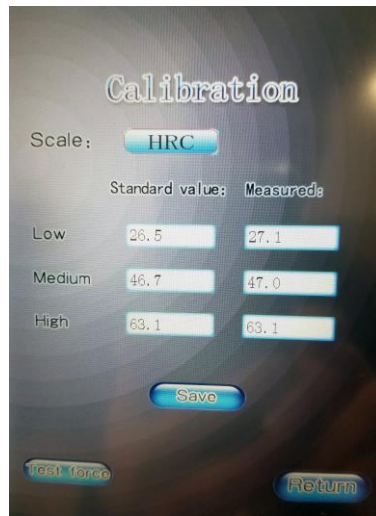

Step 3) Choose which level of the scale that your test block is in (Low, Medium, High) and touch the “Standard Value” number. The next screen will be shown as below.



Step 4) Press the numbers that reflect the exact value of your test block and then touch OK.

Step 5) Touch the “Measured” value to pull up the same screen as above. Press the numbers that reflect the average of your earlier test results and press OK.

Step 6) Press SAVE to store your new calibration and this will bring you back to the main testing screen.

Step 7) Begin taking tests on your test block and confirm that the above calibration is within tolerance. Always omit the first test result after calibration.

If the results are still out of tolerance then you can repeat the steps above.

Assuming that all of your parameters are set, you can begin taking some tests using the supplied test blocks

TECHNICAL SUPPORT: (201) 962-8352

Web Site: <http://www.starrett.com>

Included Indenters:

Rockwell B Indenter
1/16" Carbide Ball



Rockwell C Indenter
Diamond



Test Preparation:

1. Prepare the test specimen properly. Be sure that the top and bottom surfaces of the specimen are clean and free of any grease, oil dirt, etc and free of any burrs or debris.
2. For small specimens (under 3" maximum length or diameter) use the small round anvil. Use the large anvil for larger specimens. Use the V-shaped anvil for round or curved specimens.
3. Determine the proper indenter, scale and weight for the material hardness to be tested (see chart in back of this manual). Mount the required indenter in the indenter holder using the set screw. Finger tight only.

Warning!

Do not test any specimen that cannot be safely and properly positioned on and supported by the tester anvil.

Seating Your Diamond:

Caution: To ensure accuracy, mount the indenter by sliding it in the holder as far as possible and then securing the indenter by tightening the set screw finger-tight only. Place HRC test block on the small round anvil and begin by turning the handwheel clockwise until the block just touches the diamond. At this point, continue rotating the handwheel until the machine beeps. Let the machine sit idle for a few seconds and then loosen the set screw. Wait a few more seconds and then tighten the set screw back up. This will allow the diamond to be "seated" in the shank. Take the load off by turning the handwheel counter-clockwise and you can begin following instructions below.

Test Procedure

Test procedure consists of a preload of the specimen using the force of the elevation screw and a test load using the weights.

1. Mount specimen on required anvil. Rotate the elevation screw threaded collar clockwise slowly until the specimen contacts the indenter. Be sure to position specimen so the indenter contacts clean, untested material.
2. Preload the specimen by rotating the leadscrew collar slowly until the machine beeps. At this time, press the START button and the machine will apply the major load, wait for the dwell time to count down and then release the major load.

You will see this on the display:



3. Wind down the handwheel to release the test specimen from the indenter, move the specimen slightly and begin taking your next test. Please note that the first test after the machine has been turned on will automatically be omitted and will not show the test number on the display.
4. The values you get should be within +/-1 Rockwell Point of the value etched on the test block. If the value is outside of this tolerance we suggest that you contact Phase II tech support prior to calling in a calibration facility. We will help you get dialed in quickly.

When performing any physical adjustments, the power supply must be disconnected. Pay careful attention to your indenter. Be sure the shank is clean and free of rust, dirt or metal chips prior to installation.

The surface of anvil and test blocks should be clean. No oil, dirt, dust, rust or metal chips should be on these surfaces as it will cause erroneous readings.

Always keep the dust cover on the machine when not in use. Never store in damp area.

The leadscrew of the anvil should be lubricated periodically. Apply a few drops of light machine oil, then run the leadscrew up and down a few times to distribute the oil.

Never disassemble any fixed parts as this will automatically void any stated or implied warranties. If you need service, please contact tech support directly at (201) 962-7373.

If you are unsure of your hardness values you may send us results of your testing directly to us for evaluation. We will quickly respond with assistance if needed. We perform support using phone, e-mail or video chat via Skype and/or Facetime.

TECHNICAL SUPPORT: (201) 962-8352

Web Site: <http://www.starrett.com>

Operating Instructions & Parts Manual

Approximate Hardness Conversion Numbers for Non-Austenitic Steels (Rockwell C Hardness Range)^A

Rockwell C 150kgf (HRC)	Brinell Hardness Number C				Rockwell		Superficial Rockwell Number			Scleroscope HardnessD
	Vickers (HV)	10-mm Standar d ball 3000kgf (HBS)	10-mm Carbide ball 3000kgf (HBW)	Knoop 500-gf and Over (HK)	A Scale 60 kgf (HRA)	D Scale 100kg f (HRD)	15-N Scale 15-kgf (HR15N)	30-N Scale 30-kgf (HR30N)	45-N Scale 45-kgf (HR45N)	
68	940	920	85.6	76.9	93.2	84.4	75.4	97.3
67	900	895	85.0	76.1	92.9	83.6	74.2	95.0
66	865	870	84.5	75.4	92.5	82.8	73.3	92.7
65	832	...	(739)	846	83.9	74.5	92.2	81.9	72.0	90.6
64	800	...	(722)	822	83.4	73.8	91.8	81.1	71.0	88.5
63	772	...	(705)	799	82.8	73.0	91.4	80.1	69.9	86.5
62	746	...	(688)	776	82.3	72.2	91.1	79.3	68.8	84.5
61	720	...	(670)	754	81.8	71.5	90.7	78.4	67.7	82.6
60	697	...	(654)	732	81.2	70.7	90.2	77.5	66.6	80.8
59	674	...	634	710	80.7	69.9	89.8	76.6	65.5	79.0
58	653	...	615	690	80.1	69.2	89.3	75.7	64.3	77.3
57	633	...	595	670	79.6	68.5	88.9	74.8	63.2	75.6
56	613	...	577	650	79.0	67.7	88.3	73.9	62.0	74.0
55	595	...	560	630	78.5	66.9	87.9	73.0	60.9	72.4
54	577	...	543	612	78.0	66.1	87.4	72.0	59.8	70.9
53	560	...	525	594	77.4	65.4	86.9	71.2	58.6	69.4
52	544	(500)	512	576	76.8	64.6	86.4	70.2	57.4	67.9
51	528	(487)	496	558	76.3	63.8	85.9	69.4	56.1	66.5
50	513	(475)	481	542	75.9	63.1	85.5	68.5	55.0	65.1
49	498	(464)	469	526	75.2	62.1	85.0	67.6	53.8	63.7
48	484	451	455	510	74.7	61.4	84.5	66.7	52.5	62.4
47	471	442	443	495	74.1	60.8	83.9	65.8	51.4	61.1
46	458	432	432	480	73.6	60.0	83.5	64.8	50.3	59.8
45	446	421	421	466	73.1	59.2	83.0	64.0	49.0	58.5
44	434	409	409	452	72.5	58.5	82.5	63.1	47.8	57.3
43	423	400	400	438	72.0	57.7	82.0	62.2	46.7	56.1
42	412	390	390	426	71.5	56.9	81.5	61.3	45.5	54.9
41	402	381	381	414	70.9	56.2	80.9	60.4	44.3	53.7
40	392	371	371	402	70.4	55.4	80.4	59.5	43.1	52.6
39	382	362	362	391	69.9	54.6	79.9	58.6	41.9	51.5
38	372	353	353	380	69.4	53.8	79.4	57.7	40.8	50.4
37	363	344	344	370	68.9	53.1	78.8	56.8	39.6	49.3
36	354	336	336	360	68.4	52.3	78.3	55.9	38.4	48.2
35	345	327	327	351	67.9	51.5	77.7	55.0	37.2	47.1
34	336	319	319	342	67.4	50.8	77.2	54.2	36.1	46.1
33	327	311	311	334	66.8	50.0	76.6	53.3	34.9	45.1
32	318	301	301	326	66.3	49.2	76.1	52.1	33.7	44.1
31	310	294	294	318	65.8	48.4	75.6	51.3	32.5	43.1
30	302	286	286	311	65.3	47.7	75.0	50.4	31.3	42.2
29	294	279	279	304	64.8	47.0	74.5	49.5	30.1	41.3
28	286	271	271	297	64.3	46.1	73.9	48.6	28.9	40.4
27	279	264	264	290	63.8	45.2	73.3	47.7	27.8	39.5
26	272	258	258	284	63.3	44.6	72.8	46.8	26.7	38.7
25	266	253	253	278	62.8	43.8	72.2	45.9	25.5	37.8
24	260	247	247	272	62.4	43.1	71.6	45.0	24.3	37.0
23	254	243	243	266	62.0	42.1	71.0	44.0	23.1	36.3
22	248	237	237	261	61.5	41.6	70.5	43.2	22.0	35.5
21	243	231	231	256	61.0	40.9	69.9	42.3	20.7	34.8
20	238	226	226	251	60.5	40.1	69.4	41.5	19.6	34.2

TECHNICAL SUPPORT: (201) 962-8352

Web Site: <http://www.starrett.com>

Operating Instructions & Parts Manual

Approximate Hardness Conversion Numbers for Non-Austenitic Steels (Rockwell B Hardness Range)^A

Rockwell B 100kgf (HRB)	Vickers (HV)	10-mm Standard ball 3000kgf (HBS)	Knoop 500-gf and Over (HK)	Rockwell Superficial Rockwell Number				
				A Scale 60 kgf (HRA)	F Scale 60kgf (HRF)	15-T Scale 15-kgf (HR15T)	30-T Scale 30-kgf (HR30T)	45-T Scale 45-kgf (HR45T)
100	240	240	251	61.5	...	93.1	83.1	72.9
99	234	234	246	60.9	...	92.8	82.5	71.9
98	228	228	241	60.2	...	92.5	81.8	70.9
97	222	222	236	59.5	...	92.1	81.1	69.9
96	216	216	231	58.9	...	91.8	80.4	68.9
95	210	210	226	58.3	...	91.5	79.8	67.9
94	205	205	221	57.6	...	91.2	79.1	66.9
93	200	200	216	57.0	...	90.8	78.4	65.9
92	195	195	211	56.4	...	90.5	77.8	64.8
91	190	190	206	55.8	...	90.2	77.1	63.8
90	185	185	201	55.2	...	89.9	76.4	62.8
89	180	180	196	54.6	...	89.5	75.8	61.8
88	176	176	192	54.0	...	89.2	75.1	60.8
87	172	172	188	53.4	...	88.9	74.4	59.8
86	169	169	184	52.8	...	88.6	73.8	58.8
85	165	165	180	52.3	...	88.2	73.1	57.8
84	162	162	176	51.7	...	87.9	72.4	56.8
83	159	159	173	51.1	...	87.6	71.8	55.8
82	156	156	170	50.6	...	87.3	71.1	54.8
81	153	153	167	50.0	...	86.9	70.4	53.8
80	150	150	164	49.5	...	86.6	69.7	52.8
79	147	147	161	48.9	...	86.3	69.1	51.8
78	144	144	158	48.4	...	86.0	68.4	50.8
77	141	141	155	47.9	...	85.6	67.7	49.8
76	139	139	152	47.3	...	85.3	67.1	48.8
75	137	137	150	46.8	99.6	85.0	66.4	47.8
74	135	135	147	46.3	99.1	84.7	65.7	46.8
73	132	132	145	45.8	98.5	84.3	65.1	45.8
72	130	130	143	45.3	98.0	84.0	64.4	44.8
71	127	127	141	44.8	97.4	83.7	63.7	43.8
70	125	125	139	44.3	96.8	83.4	63.1	42.8
69	123	123	137	43.8	96.2	83.0	62.4	41.8
68	121	121	135	43.3	95.6	82.7	61.7	40.8
67	119	119	131	42.8	95.1	82.4	61.0	39.8
66	117	117	129	42.3	94.5	82.1	60.4	38.7
65	116	116	127	41.8	93.9	81.8	59.7	37.7
64	114	114	125	40.9	93.4	81.4	59.0	36.7
63	112	112	124	40.4	92.8	81.1	58.4	35.7
62	110	110	122	40.0	92.2	80.8	57.7	34.7
61	108	108	120	39.5	91.7	80.5	57.0	33.7
60	107	107	118	39.0	91.1	80.1	56.4	32.7
59	106	106	117	38.6	90.5	79.8	55.7	31.7
58	104	104	115	38.1	90.0	79.5	55.0	30.7
57	103	103	114	37.7	89.4	79.2	54.4	29.7
56	101	101	112	37.2	88.8	78.8	53.7	28.7
55	100	100	111	36.8	88.2	78.5	53.0	27.7
...	110	36.3	87.7	78.2	52.4	26.7
...	109	35.9	87.1	77.9	51.7	25.7
...	108	35.5	86.5	77.5	51.0	24.7
...	107	35.0	86.0	77.2	50.3	23.7
...	106	34.6	85.4	76.98	49.7	22.7
...	105	34.1	84.8	76.6	49.0	21.7
...	104	33.7	84.3	76.2	48.3	20.7
...	103	33.3	83.7	75.9	47.7	19.7
...	102	32.9	83.1	75.6	47.0	18.7
...	101	32.4	82.6	75.3	46.3	17.7
...	100	32.0	82.0	74.9	45.7	16.7
...	99	31.6	81.4	74.6	45.0	15.7
...	98	31.2	80.8	74.3	44.3	14.7
...	97	30.7	80.3	74.0	43.7	13.6
...	96	30.3	79.7	73.6	43.0	12.6
...	95	29.9	79.1	73.3	42.3	11.6
...	94	29.5	78.6	73.0	41.6	10.6
...	93	29.1	78.0	72.7	41.0	9.6
...	92	28.7	77.4	72.3	40.3	8.6
...	91	28.2	76.9	72.0	39.6	7.6
...	90	27.8	76.3	71.7	39.0	6.6
...	89	27.4	75.7	71.4	38.3	5.6
...	88	27.0	75.2	71.0	37.6	4.6
...	87	26.6	74.6	70.7	37.0	3.6
...	74.0	70.4	36.3	2.6

TECHNICAL SUPPORT: (201) 962-8352

Web Site: <http://www.starrett.com>

Weight - Load - Indentor Chart

Scale Symbol	Indentor Type	Preliminary Force N (kgf)	Total Force N (kgf)	Typical Applications
A	Spheroconical Diamond	98.07 (10)	588.4 (60)	Cemented carbides, thin steel, and shallow case hardened steel
B	1/16" Carbide Ball	98.07 (10)	980.7 (100)	Copper alloys, soft steels, aluminum alloys, malleable iron, etc.
C	Spheroconical Diamond	98.07 (10)	1471 (150)	Steel, hard cast irons, pearlitic malleable iron, titanium, deep case hardened steel, other harder than HRB 100
D	Spheroconical Diamond	98.07 (10)	980.7 (100)	Thin steel and medium case hardened steel, and pearlitic malleable iron
E	1/8" Carbide Ball	98.07 (10)	980.7 (100)	Cast Iron, Aluminum and magnesium alloys, and bearing metals
F	1/16" Carbide Ball	98.07 (10)	588.4 (60)	Annealed copper alloys and thin soft sheet metals
G	1/16" Carbide Ball	98.07 (10)	1471 (150)	Malleable irons, copper-nickel-zinc and cupro-nickel alloys
H	1/8" Carbide Ball	98.07 (10)	588.4 (60)	Aluminum, zinc and lead
K	1/8" Carbide Ball	98.07 (10)	1471 (150)	Bearing Metals and other very soft or thin materials. Use smallest ball and heaviest load that doesn't give anvil effect.
L	¼" Carbide Ball	98.07 (10)	588.4 (60)	
M	¼" Carbide Ball	98.07 (10)	980.7 (100)	
P	¼" Carbide Ball	98.07 (10)	1471 (150)	
R	½" Carbide Ball	98.07 (10)	588.4 (60)	
S	½" Carbide ball	98.07 (10)	980.7 (100)	
V	½" Carbide ball	98.07 (10)	1471 (150)	
15N	Spheroconical Diamond	29.42 (3)	147.1 (15)	Similar to A, C and D scales but for thinner gage material.
30N	Spheroconical Diamond	29.42 (3)	294.2 (30)	
45N	Spheroconical Diamond	29.42 (3)	441.3 (45)	
15T	1/16" Carbide Ball	29.42 (3)	147.1 (15)	Similar to B, F and G scales but for thinner gage material.
30T	1/16" Carbide Ball	29.42 (3)	294.2 (30)	
45T	1/16" Carbide Ball	29.42 (3)	441.3 (45)	
15W	1/8" Carbide Ball	29.42 (3)	147.1 (15)	Very Soft Material
30W	1/8" Carbide Ball	29.42 (3)	294.2 (30)	
45W	1/8" Carbide Ball	29.42 (3)	441.3 (45)	
15X	¼" Carbide Ball	29.42 (3)	147.1 (15)	
30X	¼" Carbide Ball	29.42 (3)	294.2 (30)	
45X	¼" Carbide Ball	29.42 (3)	441.3 (45)	
15Y	½" Carbide Ball	29.42 (3)	147.1 (15)	
30Y	½" Carbide Ball	29.42 (3)	294.2 (30)	
45Y	½" Carbide Ball	29.42 (3)	441.3 (45)	

TECHNICAL SUPPORT: (201) 962-8352

Web Site: <http://www.starrett.com>

